

Delta Element Steam Traps

Models: M6A, GM6

CRN: Canadian Registration Number Available

FOR PROCESS AND HEATING SYSTEMS

3 Year No Live Steam Loss Guarantee

A series of steam traps designed for low condensate capacity needs, yet incorporate a forged carbon steel body and "Y" type strainer. The M6A/GM6 utilizes thermostatic and thermodynamic forces for steam-tight shutoff for greater energy efficiency and extended seat life, with no live steam loss.

- **Maximum differential pressure** – 70 psig (4,8 bar)
- **Single blade element** – offers long-term, trouble-free service because it's not prone to dirt build-up as encountered with many other bimetal designs
- **Stainless Steel internals** – leads to longer service life since materials are highly resistant to fatigue and corrosion
- **Modulating discharge** – automatically adjusts to operating pressure and load
- **Integral strainer and check valve** – strainer protects trap from dirt while check valve prevents backflow during shutdown
- **Continuous air and CO2 venting** – maximizes heat transfer while minimizing corrosion

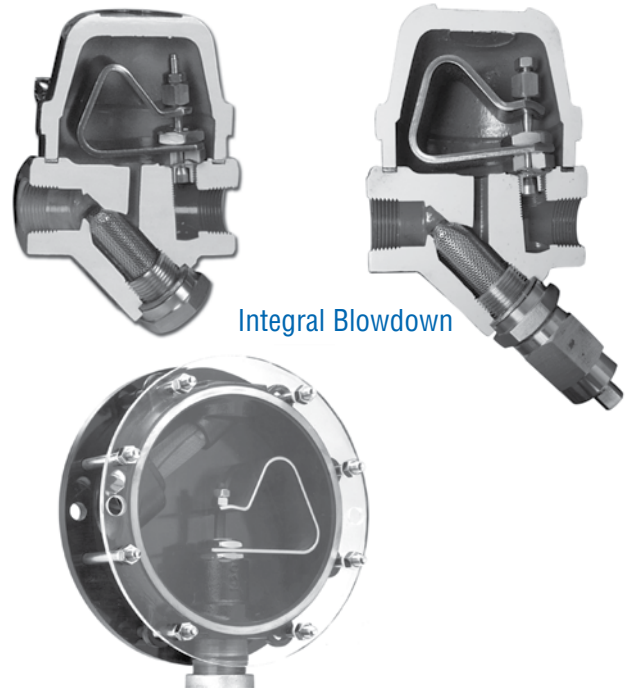

ORDERING SCHEMATIC

MODEL					6	7	8
M	0	0	6	A			

MODEL					6	7	8
G	M	0	0	6	4	1	0

6	SIZE
1	3/8" (6A)
2	1/2" (All)
3	3/4" (All)
4	1" (GM6)
5	1-1/4" (GM6)
6	1-1/2" (GM6)
7	2" (GM6)

7	CONNECTIONS
1	NPT
2	FSW*
3	150# Flange
4	300# Flange
8	BSPT
9	BSPP

8	SPECIALITIES
0	None
1	DTC*
3	Integral Blowdown*

* Not available on 2" GM3



BESTOBELLSTEAM
A Division of
Richards Industries
3170 Wasson Road
Cincinnati, OH 45209

toll free. 800.543.7311
local. 513.533.5600
fax. 513.871.0105

steam@richardsind.com
www.bestobellsteamtraps.com

FOR PROCESS AND HEATING SYSTEMS
SPECIFICATIONS (M6A & GM6 1/2" - 1-1/2" SIZES)

Maximum Differential Pressure: 70 psi (4,8 bar)

Maximum Allowable Pressure: 750 psig (51,7 bar)

Maximum Allowable Temperature: 750°F (399°C)

MATERIALS

Body & Cover: Forged Carbon Steel A105

Valve Seat & Stem: Stainless Steel 303 & 17-4

Bi-Metal: Stainless Steel

Strainer: Stainless Steel 304

Bolts: ASTM-A193, B7

Gasket: Flexible Graphite

Options: Double Threaded Strainer Cap (DTC) for blowdown valve attachment; selection of integral blowdown valves

Mounting: From horizontal to vertical (see Installation & Maintenance Instructions). Self-Draining and freeze-resistant when mounted in vertical position.

Line Sizes:

Model GM6: 1/2", 3/4", 1", 1-1/4", 1-1/2"

Model M6A: 3/8", 1/2", 3/4"

End Connections: Threaded NPT, BSPT, BSPP, SW, Raised Face Flanges (ANSI 150, 300, DIN)

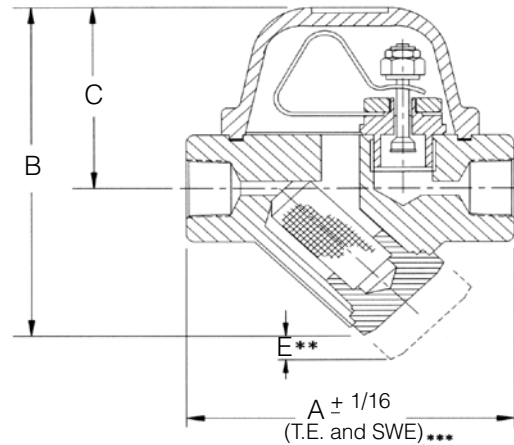

Model GM6						
1/2"-3/4"	A	B	C	D	E	Wt
inches	4	6	3.625	4	2.625	8.4 lbs
mm	102	152	92	102	67	3,8 kgs
1"	A	B	C	D	E	Wt
inches	5	6.75	3.625	4	3.50	9.9 lbs
mm	127	171	92	102	89	4,5 kgs
1-1/4", 1-1/2"	A	B	C	D	E	Wt
inches	7.125	9.50	5.875	6	4.375	33 lbs
mm	181	241	149	152	67	15 kgs
Model M6A						
3/8", 1/2", 3/4"	A	B	C	D	E	Wt
inches	4	5	3.25	3.125	2.25	5.5 lbs
mm	102	127	83	80	57	2,5 kgs

Notes: dimension D is overall width; ** dimension E is withdrawal distance for strainer, ***dimensions shown are for threaded or socket weld ends, contact factory for other dimensions

CAPACITY CHARTS: CONDENSATE CAPACITY AT OPERATING PRESSURE

Model GM6		For smaller loads to 30 psid, consider Model M3A						
Size	Operating Pressure, psi (bar)	10 (0,69)	20 (1,38)	30 (2,07)	40 (2,76)	50 (3,45)	60 (4,14)	70 (4,83)
1/2"	Cold start-up, lbs/hr	1800	3000	3800	4650	5200	5800	6200
	Hot (Dripleg), lbs/hr	580	700	760	820	860	880	900
3/4"	Cold start-up, Kg/hr	813	1360	1723	2109	2358	2630	2812
	Hot (Dripleg), Kg/hr	263	317	344	371	390	399	408
1"	Cold start-up, lbs/hr	3500	6400	8100	8900	9400	9600	9800
	Hot (Dripleg), lbs/hr	1100	1340	1520	1590	1650	1700	1750
	Cold start-up, Kg/hr	1587	2903	3674	4037	4263	4354	4445
	Hot (Dripleg), Kg/hr	498	607	689	721	748	771	793
1-1/4" & 1-1/2"	Cold start-up, lbs/hr	8000	14000	18000	21000	23000	25000	26000
	Hot (Dripleg), lbs/hr	3100	3350	3550	3700	3800	3850	3900
	Cold start-up, Kg/hr	3628	6350	8164	9525	10432	11340	11793
	Hot (Dripleg), Kg/hr	1406	1519	1610	1678	1723	1746	1769
Model M6A		Consider "GM10" Series traps in this range						
Size	Differential Pressure, psi (bar)	10 (0,69)	20 (1,38)	30 (2,07)	40 (2,76)	50 (3,45)	60 (4,14)	70 (4,83)
3/8"	Cold start-up, lbs/hr	1200	1900	2500	2900	3300	3800	4000
	Hot (Dripleg), lbs/hr	130	160	190	200	210	220	230
1/2"	Cold start-up, Kg/hr	544	861	1134	1315	1496	1723	1814
	Hot (Dripleg), Kg/hr	58	72	86	90	95	99	104

Note: Flow rates are based on discharge to atmospheric pressure, valid for back pressure up to 20% of inlet pressure. Higher back pressure requires reset of control element to obtain these capacities. Consult factory for details.

FOR PROCESS AND HEATING SYSTEMS
SPECIFICATIONS (GM6 2" SIZE)

Maximum Differential Pressure: 70 psi (4,8 bar)
 Maximum Allowable Pressure: 120 psig (8,3 bar)
 Maximum Allowable Temperature: 450°F (232°C)

MATERIALS

Body: Ductile Iron A395
 Cover: Carbon Steel A516 Gr. 70
 Valve Seat & Stem: Stainless Steel 303 & 17-4
 Bi-Metal: Stainless Steel NiCr
 Strainer: Stainless Steel 304
 Bolts: ASTM-A193, B7
 Gasket: Flexible Graphite
 Options: Double Threaded Strainer Cap (DTC) for blowdown valve attachment; blowdown valve to fit 3/8" DTC for in-line strainer blowdown
 Mounting: From horizontal to vertical (see Installation & Maintenance Instructions). Self-draining and freeze-resistant when mounted in vertical position.
 Line Sizes: 2"
 End Connections: Threaded (NPT), ANSI 150 & 300 raised face flange

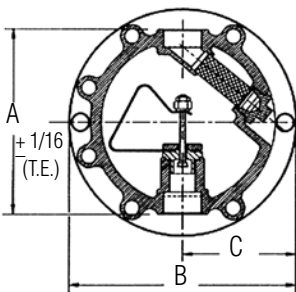
DIMENSIONS

Model GM6 (2")						
2	A	B	C	D	Wt	
inches	10.9	13.4	6.75	4.56	70 lbs	
mm	277	340	171	116	32 kgs	

Notes: dimension D is overall width

CAPACITY CHARTS: CONDENSATE CAPACITY AT OPERATING PRESSURE

Size	Differential Pressure, psi (bar)	Model GM6						
		10 (0.69)	20 (1.38)	30 (2.07)	40 (2.76)	50 (3.45)	60 (4.14)	70 (4.83)
2"	Cold start-up, lbs/hr	15000	25000	31000	36000	42000	44000	46000
	Hot (Dripleg), lbs/hr	4400	6000	7200	8000	8500	8900	9200

Note: Flow rates are based on discharge to atmospheric pressure, valid for back pressure up to 20% of inlet pressure. Higher back pressure requires reset of control element to obtain these capacities. Consult factory for details.

PRINCIPLES OF OPERATION

At the heart of every Bestobell steam trap is the unique delta-shaped element, a rugged single blade bimetal formed from high grade stainless steels. Coupled with the valve seat and stem, the element forms a single moving part that is unaffected by dirt and wear. The design provides a sophisticated force balanced valve that utilizes both *thermostatic* and *thermodynamic* forces to provide modulating discharge, and prevent the loss of live steam.

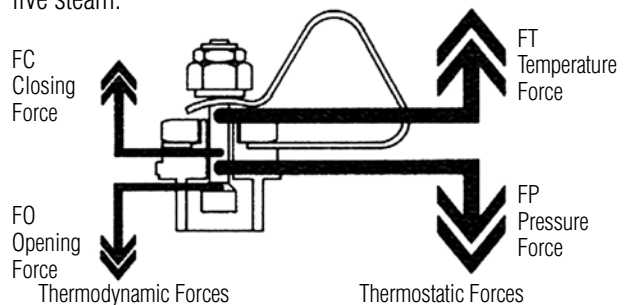

The *thermostatic* effect combines a temperature closing force (FT) generated by the element, and a pressure opening force (FP) generated by the differential pressure across the seat. When condensate temperature approaches that of saturated steam, bimetal expansion raises the stem to close the control valve. Lower temperature condensate, however, relaxes the bimetal to open the valve. With this valve opening, the system differential pressure acts on the diameter of the plug providing an increase in opening force and discharge capacity.

The *thermodynamic* forces are introduced through a three stage orifice containing an expansion chamber forced between the seat and the skirt of the valve stem. The controlled generation of flash steam within this chamber increases the intermediate pressure and resultant opening force (FO) on the valve to increase hot discharge capacity. When the temperature increases, and discharge decreases, the flashing takes place closer to the seat at the entrance to the expansion chamber. A sudden reduction in the opening force allows the closing force (FC) to take over and pull the valve tightly onto the seat. This assures tight shutoff preventing loss of live steam.