



Design and applications

The DDM orifice is designed to measure and control the flow of liquids and gases.

The device works according to the principle of differential pressure. The differential pressure at the orifice is proportional to the square of the volume rate of flow through the pipeline.

The DDM-DN orifice is fitted between flanges in the pipeline. The DDM-Rp/Gi/Ga orifice is installed in the pipeline using pipe unions or with either internal or external thread. The region of steady flow should be 6 DN upstream of the installation point and 4 DN downstream of the installation point.

The DDM orifice can be equipped with commercially available electrical or mechanical differential-pressure gauges/switches or transmitters.

DDM

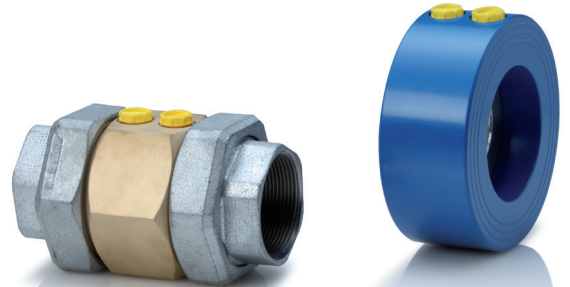

- **installation between flanges as per DIN EN 1092-1**
- **internal and external threads as per DIN EN ISO 228**
- **pipe union as per DIN EN 10226-1 (ISO 7-1)**
- **calibrated to customer specifications for liquids and gases**
- **horizontal or vertical installation**
- **no wear, no moving parts**
- **accuracy 2,5 % of full-scale range**
- **optionally**
 - **limit value switch**
 - **differential pressure gauge/-transmitter in various designs**
 - **explosion-proof design**

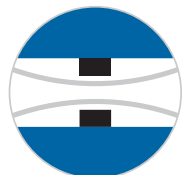

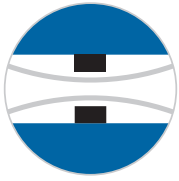

DDM

Differential pressure flow meters

Type series

DDM-DN	orifice for in-between flange assembly
DDM-Rp	orifice with pipe union connection
DDM-Gi	orifice with internal thread
DDM-Ga	orifice with external thread
DDM Ex	explosion proof design

Technical data

Measuring principle	differential pressure at the orifice
Differential pressure ¹⁾	air: 5 - 1000 mbar H2O: 100 - 1000 mbar
Pressure loss	ca. 40 % of differential pressure
Pressure resistance strength DDM	PN 16 (Please note the pressure resistance of the display unit)
Perm. ambient temperature	-10 ... +70 °C
Perm. media temperature ²⁾	standard -10 ... +70 °C max. 130 °C (insulated line) optionally HT design above 130 °C
Between flanges (DN)	PN 10 or PN 16 in accordance with DIN EN 1092-1, shape A & B
Pipe union (Rp)	two-part pipe fitting: insert with cylindrical internal thread acc. to DIN EN 10226-1 (ISO 7-1)
Internal thread (Gi)	cyl. internal fastening screw thread in accordance with DIN EN ISO 228
External thread (Ga)	cyl. external fastening screw thread in accordance with DIN EN ISO 228 T1.
Explosion protection	Manufacturer's declaration acc. to 2014/34/EU Category 3, Zone 2, T6 - T1

¹⁾ other differential pressure on request

²⁾ media must not freeze

Materials

DDM-DN	
Ring	S355, optionally 1.4571
Corrosion protection	Epoxy powder coating, traffic blue (RAL 5017) glossy
Corrosion class	C3
Orifice	1.4571
DDM-Rp, -Gi, -Ga	
Pipe union	malleable cast iron, zinc plated (Rp only)
Orifice	brass
Seals	NBR, others on request

other materials on request

Dimensions DDM-DN

DN	d ₄	L
40	88	55
50	102	55
65	122	55
80	138	55
100	158	55
125	188	55
150	212	55
200	268	55

Dimensions DDM-Rp

Rp	L ₁	L ₂	SW
¼	80	124	41
⅜	80	128	46
½	80	128	46
¾	80	128	50
1	80	136	60
1 ¼	80	146	70
1 ½	80	149	70
2	90	164	85

Dimensions DDM-Gi/DDM-Ga

Gi	Ga	L ₁	SW
¼	¾	80	41
⅜	¾	80	46
½	1 ⅛	80	46
¾	1 ¼	80	50
1	1 ½	80	60
1 ¼	2	80	70
1 ½	2 ¼	80	70
2	2 ¾	90	85

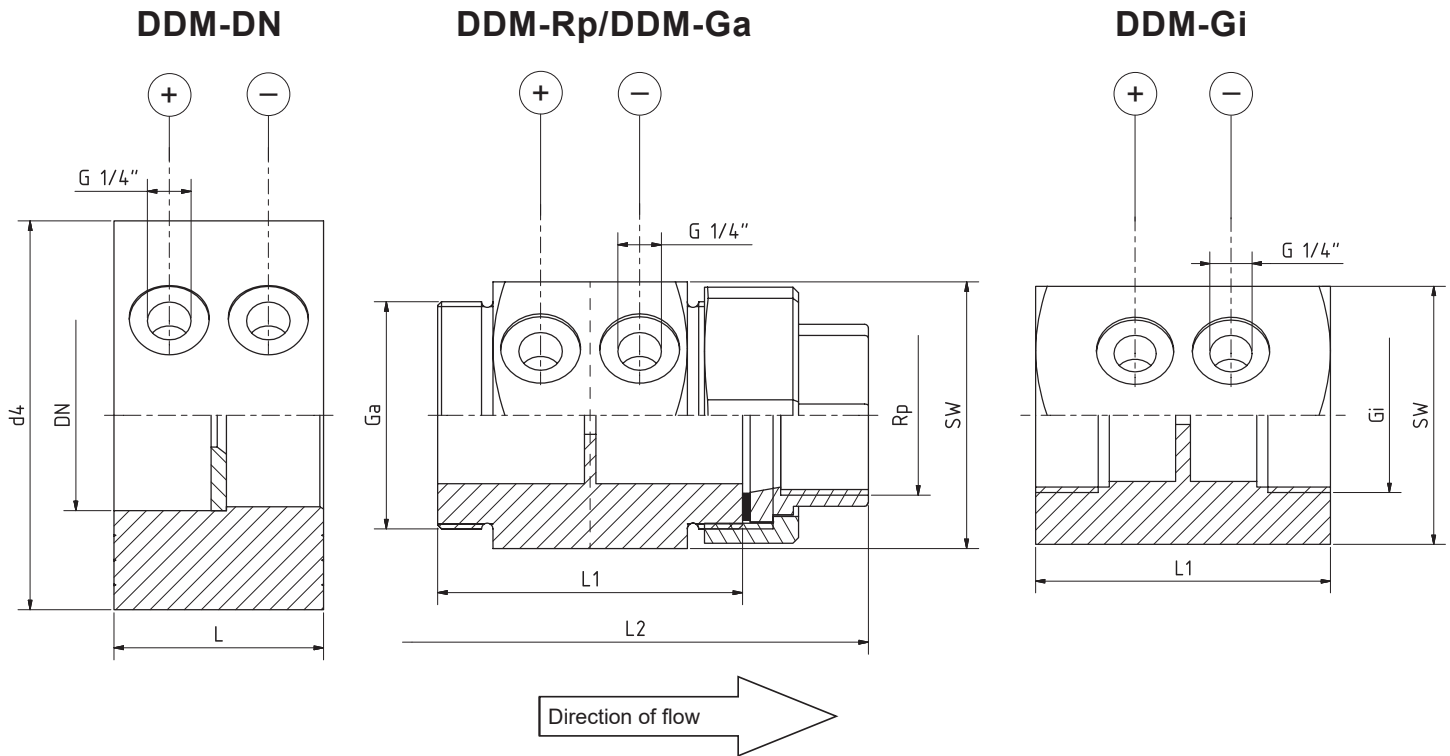

Measuring ranges for water

Connection: screwed pipe union /
internal thread / for external thread

Rp / Ga / Gi	smallest measuring range [m³/h] H₂O		largest measuring range [m³/h] H₂O	
¼	0,05	- 0,3	0,2	- 1,2
⅜	0,05	- 0,4	0,4	- 2,3
½	0,1	- 0,7	0,75	- 4,5
¾	0,2	- 1,3	1,4	- 8,5
1	0,35	- 2	2,25	- 13,5
1¼	0,6	- 3,5	4	- 24
1½	0,85	- 5	5,35	- 32
2	1,25	- 7,5	8,65	- 52

other measuring ranges on request

Measuring ranges for air

Connection: screwed pipe union /
internal thread / for external thread

Rp / Ga / Gi	smallest measuring range [m³/h] air ¹⁾		largest measuring range [m³/h] air ¹⁾	
¼	0,5	- 3	1,3	- 8
⅜	0,8	- 5	2,3	- 14
½	1	- 6	3,5	- 21
¾	1,3	- 8	7,5	- 45
1	2,0	- 12	9	- 54
1¼	4,0	- 24	18	- 108
1½	5,8	- 35	25	- 150
2	8,3	- 50	45	- 270

¹⁾at STP (0 °C and 1013 mbar) in-between ranges possible

Connection for in-between flange assembly

DN	smallest measuring range [m³/h] H₂O		largest measuring range [m³/h] H₂O	
40	0,85	- 5	5,35	- 32
50	1,2	- 7	8,7	- 52
65	2	- 12	13	- 78
80	3	- 18	19,7	- 118
100	4,7	- 28	30,7	- 184
125	7,3	- 44	48	- 288
150	10,7	- 64	68,8	- 413
200	18,8	- 113	122,5	- 735

other measuring ranges on request

Connection for in-between flange assembly

DN	smallest measuring range [m³/h] air ¹⁾		largest measuring range [m³/h] air ¹⁾	
40	5,8	- 35	25	- 150
50	9	- 54	45	- 270
65	13,5	- 81	83	- 500
80	20	- 120	125	- 750
100	35	- 210	142	- 850
125	60	- 360	292	- 1750
150	75	- 450	433	- 2600
200	125	- 750	667	- 4000

¹⁾at STP (0 °C and 1013 mbar) in-between ranges possible

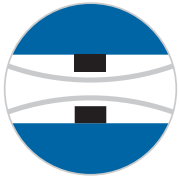

DDM

Differential pressure flow meters

Proper use

The user is responsible for assessing the suitability of the flow meters for his case of application, for use as prescribed, and for material compatibility regarding the fluid product used in his process.

The manufacturer shall not be liable for any damage arising from incorrect or improper use of the devices.

The equipment from **Kirchner und Tochter** has been tested in compliance with applicable CE-regulations of the European Community. The respective declaration of conformity is available on request. Subject to change without notice. The current valid version of our documents can be found at www.kt-flow.de

The **Kirchner und Tochter** QM-System is certified in accordance with DIN EN ISO 9001:2015. The quality is systematically adapted to the continuously increasing demands.